

1.25G SINGLE-MODE DUAL FIBER SFP MODULE 1310NM, 20KM: (KL-SFP-SM-GE)



PRODUCT DETAILS:

- SFP package with LC connector;
- 1310nm VCSEL Laser and PIN photo detector;
- Up to 20km transmission;
- +3.3V single power supply;
- LVPECL compatible data input/output interface;
- Low EMI and excellent ESD protection;

SPECIFICATIONS:

Parameter	Symbol	Minimum	Typical	Maximum	Units
Absolute Maximum Ratings					
Storage Temperature	Tst	-40	-	+85	°C
Supply Voltage	Vcc	0	-	+3.6	V
Operating Relative Humidity	RH	5	-	95	%
Operation Environment					
Supply Voltage	Vcc	3.15	3.3	3.45	V
Operating Case Temperature	Tc	0		+70	
Power Dissipation				1	W
Data Rate			1.25		Gbps
Optical Characteristics					

Transmitter Section					
Center Wavelength	□o	1260	1310	1360	nm
Average Output Power	□□	-	-	4	nm
Extinction Ratio	Po	-9	-	-3	dBm
Rise/Fall Time(20%~80%)	Er	8	-		dB
Total jitter	Tr/Tf			300	ps
Optical Eye Diagram	IEEE 802.3z and ANSI Fibre Channel Compatible				
Receiver Section					
Center Wavelength	□o	1260		1620	nm
Receiver Sensitivity	Rsen			-22	dBm
Receiver Overload	Rov	-3			dBm
Return Loss		12			dB
LOS Assert	LOSA	-36			dBm
LOS Dessert	LOSD			-23	dBm
LOS Hysteresis		0.5		5	
Electrical Characteristics					
Transmitter Section					
Input Differential Impendence	Zin	90	100	110	Ohm
Data Input Swing Differential	Vin	500		2400	mV
TX Disable	Disable		2.0		Vcc
	Enable		0		0.8
TX Fault	Assert		2.0		Vcc
	Deassert		0		0.8
Receiver Section					
Output differential impendence	Zout	-	100	-	Ohm
Data Input Swing Differential	Vout	370	-	2000	mV
Rx_LOS	Assert	-	2.0	-	Vcc
	Deassert	-	0	-	0.8

Add.	Field Size (Bytes)	Name of Field	HEX	Description
EEPROM INFORMATION (A0)				
0	1	Identifier	03	SFP
1	1	Ext. Identifier	04	MOD4
2	1	Connector	07	LC
3-10	8	Transceiver	00 00 00 02 12 00 0D 01	Transmitter Code
11	1	Encoding	01	8B10B

12	1	BR, nominal	0D	1250M bps
13	1	Reserved	00	
14	1	Length (9um)- km	14	20km
15	1	Length (9um)	64/C8/FF	
16	1	Length (50um)	00	
17	1	Length (62.5um)	00	
18	1	Length (copper)	00	
19	1	Reserved	00	
20-35	16	Vendor name	57 49 4E 54 4F 50 20 20 20 20 20 20 20 20 20 20	KORE LINK
36	1	Reserved	00	
37-39	3	Vendor OUI	00 00 00	
40-55	16	Vendor PN	XX XX XX XX XX XX XX XX XX XX XX XX XX XX XX XX	ASC II
56-59	4	Vendor rev	31 2E 30 20	V1.0
60-61	2	Wavelength	05 1E	1310nm
62	1	Reserved	00	
63	1	CC BASE	XX	Check sum of byte 0~62
64-65	2	Options	00 1A	LOS, TX_DISABLE, TX_FAULT
66	1	BR, max	32	50%
67	1	BR, min	32	50%
68-83	16	Vendor SN	00 00 00 00 00 00 00 00 00 00 00 00 00 00 00 00	Unspecified
84-91	8	Vendor date code	XX XX XX 20	Year, Month, Day
92-94	3	Reserved	00	
95	1	CC_EXT	XX	Check sum of byte 64~94
96-255	160	Vendor specific		

Parameter	Range	Accuracy	Unit	Calibration
Diagnostics				
Temperature	0 ~ 70	±5	°C	Internal
Voltage	3.15 ~ 3.45	0.1	V	Internal
Bias Current	10 ~ 80	±2	mA	Internal

Tx Power	-9 ~ -3	±2	dBm	Internal
Rx Power	-26~-3	±3	dBm	Internal

Pins	Name	Description	NOTE
Pin Description			
1	VeeT	Transmitter Ground	-
2	Tx Fault	Transmitter Fault Indication	1
3	Tx Disable	Transmitter Disable	2
4	MOD DEF2	Module Definition 2	3
5	MOD DEF1	Module Definition 1	3
6	MOD DEF0	Module Definition 0	3
7	Rate Select	Not Connected	-
8	LOS	Loss of Signal	4
9	VeeR	Receiver Ground	-
10	VeeR	Receiver Ground	-
11	VeeR	Receiver Ground	-
12	RD-	Inv. Received Data Output	5
13	RD+	IReceived Data Output	5
14	VeeR	Receiver Ground	-
15	VccR	Receiver Power	-
16	VccT	Transmitter Power	-
17	VeeT	Transmitter Ground	-
18	TD+	Transmit Data Input	6
19	TD-	Inv. Transmit Data Input	6
20	VeeT	Transmitter Ground	-

OUTLINE DRAWING (mm):

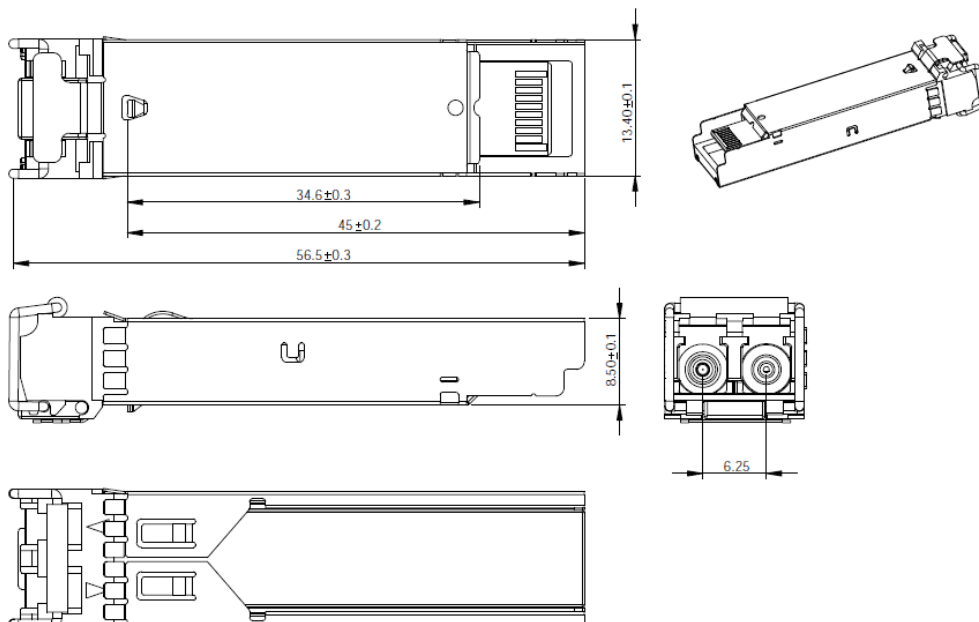

APPLICATION:

- 1.25 Gb/s 1000Base-SX Ethernet;
- 1.06 Gb/s Fiber Channel;

NOTES:

- TX Fault is an open collector output, which should be pulled up with a 4.7k~10kΩ resistor on the host board to a voltage between 2.0V and Vcc+0.3V. Logic 0 indicates normal operation; logic 1 indicates a laser fault of some kind. In the low state, the output will be pulled to less than 0.8V;
- TX Disable is an input that is used to shut down the transmitter optical output. It is pulled up within the module with a 4.7k~10kΩ resistor. Its states are:
Low (0~0.8V): Transmitter on (>0.8V, <2.0V): Undefined High (2.0~3.465V): Transmitter Disabled Open: Transmitter Disabled
- MOD-DEF 0, 1, 2 are the module definition pins. They should be pulled up with a 4.7k~10kΩ resistor on the host board. The pull-up voltage shall be VccT or VccR.
MOD-DEF 0 is grounded by the module to indicate that the module is present
MOD-DEF 1 is the clock line of two wire serial interface for serial ID
MOD-DEF 2 is the data line of two wire serial interface for serial ID.
- LOS is an open collector output, which should be pulled up with a 4.7k~10kΩ resistor on the host board to a voltage between 2.0V and Vcc+0.3V. Logic 0 indicates normal operation; logic 1 indicates loss of signal. In the low state, the output will be pulled to less than 0.8V.
- These are the differential receiver output. They are internally AC-coupled 100Ω differential lines which should be terminated with 100Ω (differential) at the user SERDES.
- These are the differential transmitter inputs. They are AC-coupled, differential lines with 100Ω differential termination inside the module.

HEAD QUARTERS:

BARTYCKA 22B M21A 00-716
WARSAWA, POLAND.

For more information visit us at
www.korekonekt.com